

All MotoAmerica Junior Cup Teams Updated 1/21/2020

The following balancing regulations have been updated:

From and including 2020 Round 1 Road Atlanta the following will apply:

-Yamaha YZF-R3 and YZF-R3A may be equipped with the GYTR engine kit B7P-RACE3-19-00. **Contact Tom Halverson at tom_halverson@yamaha-motor.com** to order.

-Kawasaki 400 requires the fitting of a restrictor plate between the cylinder head and intake boot. (MA-2019-30). Restrictor plates may be obtained by going to <https://motoamerica.com/product/restrictor-plate/>. The cost is \$25 and includes shipping anywhere in the United States.

For all manufacture's; ECU software, engine build specs, data logging and suspension components may only be used if allowed in the approved products and specifications outlined in the "2020 Approved List". The "2020 Approved List" may be found at: <https://americanmotorcyclist.com/racing/road-racing-rules/>

All machines must be fitted with a HM Quickshifter or Solo Engineering WSS300 Electronics package. HM Quickshifter firmware and configuration software must be at V3.1. Software updates, if needed, will be available and take place during technical control. **Contact Solo Engineering at <https://soloengineering.com/product/wss300-control-electronics-kit/>** to order WSS300 spec electronics. **Use the HM Order Form to order the series spec HM Quickshifter. Additional contact information: sales@hmquickshifter.com, support@hmquickshifter.com, phone +44 (0)1795 429 168**

2.9.1 Minimum weight

The minimum weight for each model is as follows:

Brand	Bike Weight		Combined Minimum Bike and Rider Weight*
	Hard Minimum	Soft Maximum	
CBR500R	147 kg	160 kg	210 kg
KTM RC 390/ R	133 kg	146 kg	202 kg
Ninja 300	133 kg	146 kg	200 kg
Ninja 400	137 kg	150 kg	210 kg
YZF-R3 (All)	137 kg	150 kg	204 kg

- Combined weight is the weight of the rider (in full racing equipment) and bike, as used on track.
- IF the bike has achieved or exceeded the 'Soft Maximum Weight' then the combined minimum weight does not need to be reached. The bike alone may never at any time be below the 'Hard Minimum Weight'. This limits the maximum amount of ballast that can be added to the machines.

2.9.9.1 Ignition / Engine Control System (ECU)

- The initial revlimiter setting for each machine is as follows:

Machine:	Max rpm
Honda CBR500R	10,000 rpm
Kawasaki Ninja 300 (EX300ADF)	13,000 rpm
Kawasaki Ninja 400	10,350 rpm
Yamaha YZF-R3 (A,Euro 3, Euro 4, Kit)	13,000 rpm
KTM RC390/R	11,000 rpm

The following modification's will be allowed:

Yamaha R3 and Yamaha R3A:

GYTR Engine Kit

Airbox air filter cover may be reduced

Airbox intake tube may be removed (rubber)

Honda CBR500R:

Air funnel may be shortened (with no limit)

Airbox intake tube/funnel may be removed (this part is the filter mount)

Yamaha R3:



May be modified as such:



This rubber part may be removed:

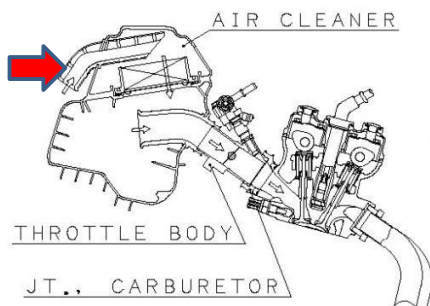

The following parts (Air Funnels) may be shortened freely:

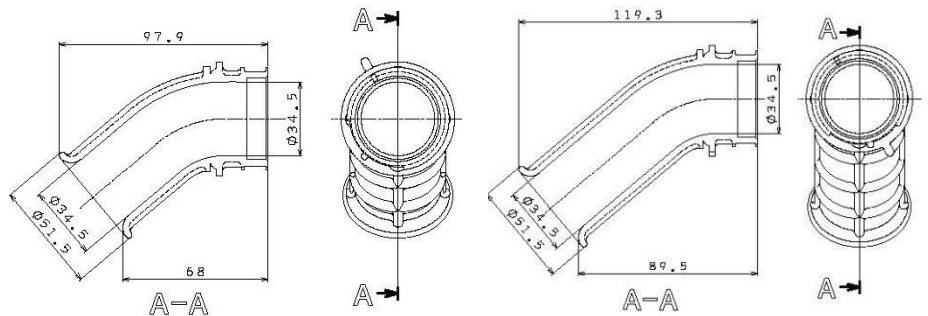

Honda CBR500R:

This may be removed (red arrow):

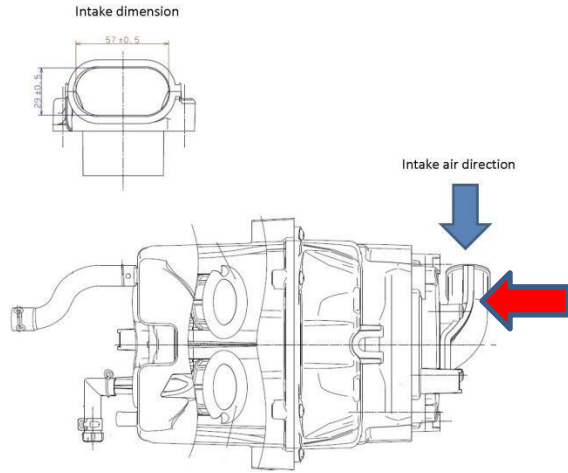

This may be opened to the full extent of the air filters opening (air filter is attached to the bottom):



Remove this area:

Additionally, Air funnels may be shortened freely.

The rulebook is available here <http://www.americanmotorcyclist.com/Racing/Story/road-racing-rules>

Please email technicaldirector@motoamerica.com for any additional questions.